

Experimental observation of generalized time-lagged chaotic synchronization

Liqliang Zhu¹ and Ying-Cheng Lai^{1,2}

¹Department of Electrical Engineering, Center for Systems Science and Engineering Research, Arizona State University, Tempe, Arizona 85287

²Departments of Mathematics and Physics, Arizona State University, Tempe, Arizona 85287

(Received 11 June 2001; published 26 September 2001)

We investigate, experimentally, synchronization in coupled chaotic oscillators in the presence of large parameter mismatches and identify a different phenomenon: generalized time-lagged synchronization. Specifically, we find that there can be a functional relation between time-lagged dynamical variables of the coupled oscillators in wide parameter regimes.

DOI: 10.1103/PhysRevE.64.045205

PACS number(s): 05.45.-a

Synchronization in chaotic systems was first described in Ref. [1], but the phenomenon did not attract much attention until the pioneering work by Pecora and Carroll in 1990 [2]. Chaotic systems are characterized by a sensitive dependence on initial conditions, and indeed, synchronization between even identical chaotic systems is an intriguing problem. For a system of two coupled chaotic oscillators: $d\mathbf{x}/dt = \mathbf{f}(\mathbf{x}, \mathbf{y})$ and $d\mathbf{y}/dt = \mathbf{g}(\mathbf{x}, \mathbf{y})$, where \mathbf{x} and \mathbf{y} are phase-space variables of the two systems, respectively, and \mathbf{f} and \mathbf{g} are the corresponding nonlinear velocity fields, synchronization in a direct sense means the following: $|\mathbf{x}(t) - \mathbf{y}(t)| \rightarrow 0$ as $t \rightarrow \infty$. Typically, synchronization can occur in the following *generalized* sense [3]: $\mathbf{y}(t) = \mathbf{h}[\mathbf{x}(t)]$, where \mathbf{h} represents a functional relation between \mathbf{x} and \mathbf{y} . When the coupled chaotic oscillators are only slightly nonidentical, i.e., $\mathbf{f} \approx \mathbf{g}$, phenomena can arise such as phase synchronization in which the chaotic rotations of the coupled oscillators tend to follow each other, and time-lagged synchronization [4,5] in which dynamical variables of the oscillators evolve in an approximately identical manner but with a fixed time delay.

The focus of this paper is on time-lagged chaotic synchronization. Existing works in this direction have been exclusively on coupled, nearly identical nonlinear oscillators that generate simple, single-scroll type of chaotic attractors for which proper rotations can be defined in the phase space [5–8]. In such a setting, time-lagged synchronization occurs in a *direct* sense, as follows: $\mathbf{y}(t) \approx \mathbf{x}(t + \tau)$, where $\tau \neq 0$ is the lag time. The purpose of this paper is to address, experimentally, the question of whether time-lagged synchronization can occur when there is a large parameter mismatch and when the structure of the chaotic attractor is more complicated (e.g., double-scroll chaotic oscillator). We utilize coupled chaotic electronic circuits with significant parameter mismatch and find lag synchronization in the following generalized sense:

$$\mathbf{y}(t) \approx \mathbf{H}[\mathbf{x}(t + \tau)], \quad (1)$$

where \mathbf{H} is a function (not necessarily smooth). This result is different in the sense that it extends and generalizes the notion of chaotic time-lagged synchronization, which can be potentially useful for applications such as anticipation of chaotic synchronization [9], and consequently, forecasts of chaotic states.

To motivate our experimental investigation, we briefly describe the mechanism of time-lagged chaotic synchronization in coupled, slightly nonidentical chaotic oscillators [5]. Consider the following system of two coupled Rössler [10] oscillators utilized in Ref. [5] to first report chaotic lag synchronization: $dx_{1,2}/dt = -\omega_{1,2}y_{1,2} - z_{1,2} + \epsilon(x_{2,1} - x_{1,2})$, $dy_{1,2}/dt = \omega_{1,2}x_{1,2} + 0.165y_{1,2}$, and $dz_{1,2}/dt = 0.2 + z_{1,2}(x_{1,2} - 10.0)$, where $\omega_1 \neq \omega_2$ but $\omega_1 \approx \omega_2 \approx 1.0$. Each oscillator produces a single-scroll chaotic attractor with a unique center of rotation, due to a well defined rotational structure embedded in the attractor, which is generated by a harmonic oscillator: $d\hat{x}/dt = -\omega\hat{y}$ and $d\hat{y}/dt = \omega\hat{x}$, where \hat{x} and \hat{y} correspond to the position and velocity of the oscillator, respectively, and ω is the frequency of rotation in the (x, y) plane. The cylindrical coordinate (r, θ, z) can then be utilized to better characterize the chaotic rotation associated with the ideal harmonic oscillator embedded in the (x, y) equations. In general, for chaotic rotations, one can write $\theta_{1,2}(t) = \langle \omega \rangle t + \phi_{1,2}(t)$, where $\phi_{1,2}(t)$'s represent chaotic fluctuations and are “slow” phase variables (the $\langle \omega \rangle t$ term represents the “fast” phase variable). Averaging out the fast phase variables in the $\theta_{1,2}$ equations, one obtains the following equation for $\Delta\phi \equiv \phi_1 - \phi_2$ [5]: $d\Delta\phi/dt \approx (\omega_1 - \omega_2) - (\epsilon/2)(r_2/r_1 + r_1/r_2)\sin(\phi_1 - \phi_2)$. The phase-locking condition $d\Delta\phi/dt = 0$ thus yields the following relation:

$$\phi_1 - \phi_2 \approx \sin^{-1} \frac{2(\omega_1 - \omega_2)r_1r_2}{\epsilon(r_1^2 + r_2^2)}. \quad (2)$$

Assuming constant slow phases in the $r_{1,2}$ and $z_{1,2}$ equations and performing averaging, one obtains four differential equations in (r_1, z_1) and (r_2, z_2) that represent a system of two coupled, periodically driven oscillators, with the following driving terms for oscillators 1 and 2, respectively: $F_{1,2}(t) \sim \cos(\langle \omega \rangle t + \phi_{1,2})$. If the phase difference of these driving terms is neglected, the equations in (r_1, z_1) and (r_2, z_2) represent a system of two coupled, identical chaotic oscillators. It is shown in Ref. [5] that the effect of the nonidentical driving terms $F_{1,2}(t)$ is equivalent to a fixed time lag between the two oscillators in the sense that, if time-lagged variables are introduced, say: $\tilde{r}_2(t) = r_2(t + \tau)$ and $\tilde{z}_2(t) = z_2(t + \tau)$, where $\tau = (\phi_1 - \phi_2)/\langle \omega \rangle$, then the equations in (r_1, z_1) and (r_2, z_2) describe the dynamics of two coupled,

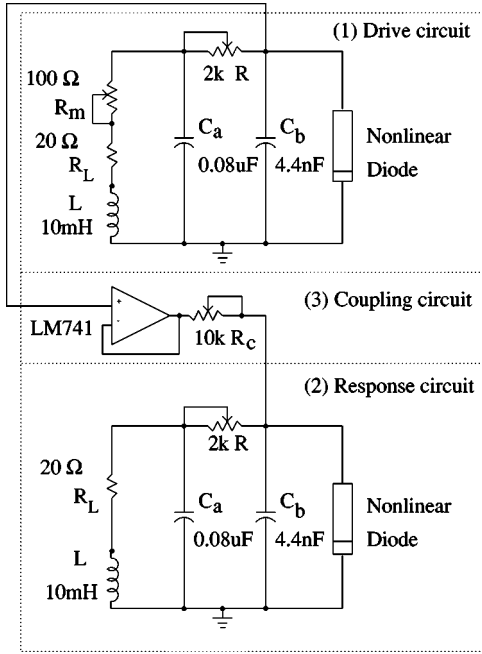

FIG. 1. Schematic diagram of the system of pair of unidirectionally coupled Chua's circuits, where R_m can be adjusted to introduce substantial mismatch between the circuits.

identical oscillators driven by the same force. Time-lagged synchronization $r_1(t) \approx \tilde{r}_2(t)$ and $z_1(t) \approx \tilde{z}_2(t)$, is thus expected. For small parameter mismatch, Eq. (2) yields $\phi_1 - \phi_2 \approx \text{constant} \sim (\omega_1 - \omega_2)$, so that an approximately constant lag time τ is expected.

The above heuristic analysis [5] for chaotic time-lagged synchronization is valid under the following two assumptions: (1) the chaotic oscillator is of the Rössler-type, which possesses a well defined structure of rotation (so that a cylindrical coordinate can be employed for theoretically predicting time-lagged synchronization), and (2) the mismatch between the oscillators is small so that a constant lag time can be ensured. In situations where these two conditions are violated, it is not clear whether time-lagged synchronization can be theoretically predicted and analyzed. In what follows we address this issue experimentally.

Our experimental system consists of two unidirectionally coupled Chua's circuits [11], as shown schematically in Fig. 1. The differential equations that describe the circuits are

$$\begin{aligned} \frac{dx_1}{dt} &= \frac{1}{C_b} [G(y_1 - x_1) - f(x_1)], \\ \frac{dx_2}{dt} &= \frac{1}{C_b} [G(y_2 - x_2) - f(x_2)] + \frac{x_1 - x_2}{R_c}, \\ \frac{dy_{1,2}}{dt} &= \frac{1}{C_a} [G(x_{1,2} - y_{1,2}) + z_{1,2}], \\ \frac{dz_{1,2}}{dt} &= -\frac{1}{L} (y_{1,2} + R_{1,2} z_{1,2}), \end{aligned} \quad (3)$$

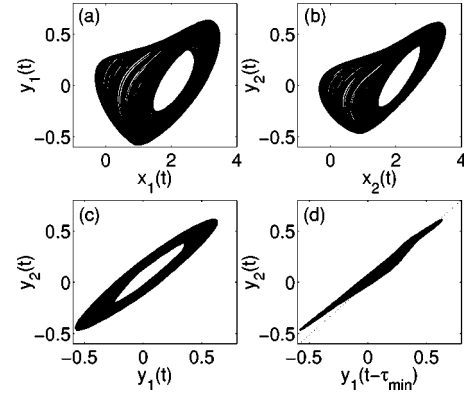

FIG. 2. Rössler-type attractors from the driver (a) and response (b) circuits for $R = 1.689 \text{ k}\Omega$, $R_c = 544 \Omega$, and $R_m = 35 \Omega$. (c) $y_1(t)$ versus $y_2(t)$; (d) $y_1(t - \tau_{min})$ versus $y_2(t)$, where $\tau_{min} = 11 \mu\text{s}$. All measurements are in volts.

where x , y , and z are proportional to the voltages across the capacitors C_b and C_a , and the current through the inductor L , respectively. The parameters in Eq. (3) are related to those in the circuit, as follows: $G = 1/R$, $R_1 = R_m + R_L$, $R_2 = R_L$, and $f(x)$ is a piecewise linear function $f(x) = G_b x + (G_a - G_b)(|x + E| - |x - E|)/2$, which is implemented by using two operational amplifiers (LM387, Harris) and six resistors [12]. The one-way coupling from circuit 1 to 2 is realized by an operational amplifier (LM741, Harris) and a resistor R_c , where R_c controls the coupling strength. All parameters in the two circuits, except R_m , are set approximately at equal values. Nonidentity between two circuits is stipulated by utilizing a nonzero resistance R_m , resulting in a controllable mismatch between R_1 and R_2 in Eq. (3). The circuits are assembled on a high-quality printed-circuit board, and the whole system is enclosed in an electromagnetic shielding box in order to minimize the influence of environmental noise. The entire system is powered by a low-ripple and low-noise power supply (HPE3631, HP). The voltage signals are recorded by using a 12-bit data acquisition board (KPCI3110, Keitley) with a sampling rate two orders of magnitude higher than the bandwidth of the signals.

We first consider the situation where both circuits, when uncoupled, generate Rössler-type of attractors. This can be achieved by tuning the resistors R in both the driving and the response circuits. Setting $R_m = 35 \Omega$ results in a substantial mismatch (about 64%) between the parameters R_1 and R_2 in Eq. (3). Figures 2(a) and 2(b) show such attractors, in the (x, y) plane, from the driving and the response circuits, respectively. The attractors are apparently distinct due to the large parameter mismatch. A typical example of lag synchronization is shown in Fig. 2(c) where $y_1(t)$ versus $y_2(t)$ is plotted. The ellipselike shape of the plot suggests a time-lagged relation between $y_1(t)$ and $y_2(t)$ [6]. Figure 2(d) shows $y_1(t - \tau_{min})$ versus $y_2(t)$, where τ_{min} is the time lag determined by examining a similarity function [5] (to be described below). We observe that the trace lies in the vicinity of the diagonal line in the $[y_1(t - \tau_{min}), y_2(t)]$ plane, indicating time-lagged synchronization. The ‘‘fattening’’ of the trace is caused by a systematic difference in the amplitudes of the chaotic rotations of the two attractors, which is due to

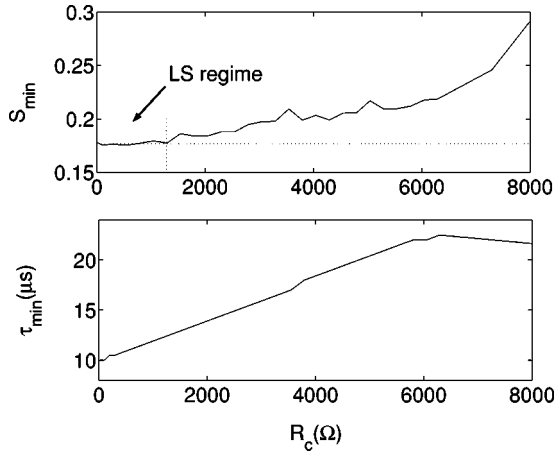

FIG. 3. S_{min} and τ_{min} versus coupling resistance R_c for $R = 1.689$ k Ω and $R_m = 35$ Ω .

the large parameter mismatch between the two circuits, and by uncontrollable noise in the laboratory.

To quantify the experimentally observed lag synchronization, we make use of the following similarity function [5]:

$$S(\tau) = \sqrt{\frac{\langle [y_2(t+\tau) - y_1(t)]^2 \rangle}{[\langle y_1^2(t) \rangle \langle y_2^2(t) \rangle]^{1/2}}}, \quad (4)$$

where $\langle \bullet \rangle$ denotes time average and τ is the lag time. Let τ_{min} be the value of τ for which $S(\tau)$ is minimum and let $S_{min} \equiv S(\tau_{min})$. Time-lagged synchronization is characterized by the following condition: $S_{min} \approx 0$ but $\tau_{min} \neq 0$. To estimate S_{min} and τ_{min} from experimental time series, we use the method described in Ref. [7], which is to examine the following cross-spectral density $P_{12}(\omega) = \int R_{12}(t') e^{-i\omega t'} dt'$, where $R_{12}(t') = \langle y_1(t) y_2(t+t') \rangle$ is the cross-correlation function. Writing $P_{12}(\omega) = A(\omega) \exp[j\Phi_{12}(\omega)]$, we see that if time-lagged synchronization occurs, i.e., $y_1(t - \tau_{min}) = y_2(t)$, then we have: $\tau_{min} = \Phi_{12}(\omega)/\omega$. The lag time is therefore approximately the slope of a linear regression of the plot of $\Phi_{12}(\omega)$ versus ω in the low-frequency regime [13]. For the circuit setting of Rössler-like attractors, S_{min} and τ_{min} versus the coupling resistance R_c are shown in Figs. 3(a) and 3(b), respectively. We see that for $R_c \lesssim 1200$ Ω , the value of S_{min} plateaus at about 0.178, which is the minimally achievable one in experiments when the similarity measure utilized is defined with respect to “direct” time-lagged synchronization between the two coupled circuits, as in Eq. (4). In this plateaued parameter region, the value of τ_{min} keeps decreasing, indicating that the lag times are larger than the minimal value that can be resolved in our experiments. Thus, it can be concluded that we have observed time-lagged synchronization, though imperfect, for $0 < R_c \lesssim 1200$ Ω for our coupled chaotic circuits with over 60% of parameter mismatch.

The remarkable finding is that the synchronization exemplified by Figs. 2(a)–2(d) can actually be considered as a *generalized* type of time-lagged synchronization, in the sense of Eq. (1). Notice from Fig. 2(d) that the plot of $y_1(t - \tau_{min})$ versus $y_2(t)$ appears to lie along an off-diagonal line

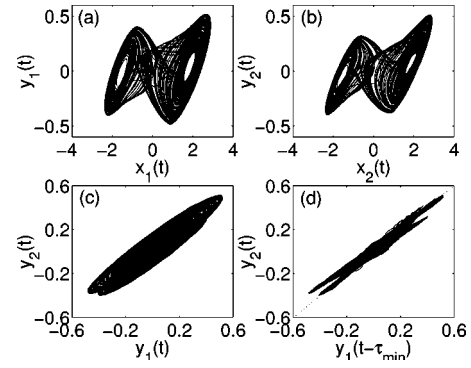

FIG. 4. Double-scroll attractors from the driving (a) and response (b) circuits for $R = 1.608$ k Ω , $R_c = 544$ Ω , and $R_m = 35$ Ω . (c) $y_1(t)$ versus $y_2(t)$; (d) $y_1(t - \tau_{min})$ versus $y_2(t)$, where $\tau_{min} = 10$ μ s. All measurements are in volts.

with a slope slightly different from unity, which suggests the following generalized relation: $y_2(t) = h[y_1(t - \tau_{min})]$, the scalar version of Eq. (1). We then define the following measure of *generalized similarity* function:

$$S^G(\tau) = \sqrt{\frac{\langle \{y_2(t) - h[y_1(t - \tau)]\}^2 \rangle}{[\langle y_1^2(t) \rangle \langle y_2^2(t) \rangle]^{1/2}}}. \quad (5)$$

Performing a simple linear regression between $y_2(t)$ and $y_1(t - \tau_{min})$, we obtain $y_2(t) = h[y_1(t - \tau_{min})] \approx 0.890y_1(t - \tau_{min}) + 0.043$, which, when substituted in Eq. (5), yields $S_{min}^G \approx 0.076$, which is substantially smaller than the value obtained from the “direct” similarity measure in Eq. (4). One can also test high-order polynomial fittings. For instance, a quadratic regression yields $y_2(t) \approx 0.033y_1^2(t - \tau_{min}) + 0.890y_1(t - \tau_{min}) + 0.039$, resulting in $S_{min}^G \approx 0.071$, which is even smaller than that obtained from a linear regression. At present there exists no systematic approach for predicting a precise mathematical relation between the corresponding time-lagged variables in coupled, nonidentical chaotic oscillators. Nonetheless, our simple computations suggest the existence of *generalized time-lagged synchronization*, which to our knowledge, has not been reported previously.

As our second set of experiments, we consider chaotic attractors that are geometrically and topologically more complicated than the Rössler-type ones, in the sense that the attractors possess multiple centers of rotations. In particular, we adjust one of the key circuit parameters, R , from $R = 1.689$ k Ω in the previous setting to $R = 1.608$ k Ω , so that each circuit, when uncoupled, exhibits a double-scroll attractor, as shown in Figs. 4(a) and 4(b) for the driving and the response circuits, respectively. The parameter mismatch is still about 64%. Because of the double-scroll structure of the chaotic attractor, the plot of $y_1(t)$ versus $y_2(t)$ consists of, approximately, two overlapped ellipses, as shown in Fig. 4(c) for $R_c = 544$ Ω . The plot of time-lag adjusted voltages $y_1(t - \tau_{min})$ versus $y_2(t)$ exhibits two approximate line segments in the vicinity of the diagonal, as shown in Fig. 4(d), where the estimated value of the lag time is $\tau_{min} \approx 10$ μ s. We have thus observed, again, time-lagged synchronization

in a generalized form. In this case, however, the functional relation between the time-lagged dynamical variables is unknown. Extensive measurements similar to those in Figs. 3(a) and 3(b) indicate that generalized time-lagged synchronization occurs when the coupling resistance is below about $1 \text{ k}\Omega$ for the parameter setting in Figs. 4(a)–4(d).

In summary, we have presented evidence that, when coupled chaotic oscillators do not possess a proper rotational structure and when the parameter mismatch between them is substantial, time-lagged synchronization can still occur, but more likely in a generalized form. It remains as an interesting question to theoretically analyze this type of synchroni-

zation, e.g., from the standpoint of the synchronization manifold [14,15]. Our experimental investigation suggests, nonetheless, that generalized time-lagged chaotic synchronization can be common in coupled, nonidentical chaotic systems.

We thank A. Raghu for assistance in the assembly of the coupled circuit system in the initial phase of the project. This work has been supported by AFOSR under Grant No. F49620-98-1-0400, by NSF under Grant No. PHY-9996454, and by Arizona State University.

-
- [1] H. Fujisaka and T. Yamada, Prog. Theor. Phys. **69**, 32 (1983); V.S. Afraimovich, N.N. Verichev, and M.I. Rabinovich, Radiophys. Quantum Electron. **29**, 747 (1986).
 - [2] L.M. Pecora and T.L. Carroll, Phys. Rev. Lett. **64**, 821 (1990).
 - [3] N.F. Rulkov, M.M. Sushchik, L.S. Tsimring, and H.D.I. Abarbanel, Phys. Rev. E **51**, 980 (1995); L. Kocarev and U. Parlitz, Phys. Rev. Lett. **76**, 1816 (1996); H.D.I. Abarbanel, N.F. Rulkov, and M. Sushchik, Phys. Rev. E **53**, 4528 (1996); B. Hunt, E. Ott, and J.A. Yorke, *ibid.* **55**, 4029 (1997).
 - [4] M.G. Rosenblum, A.S. Pikovsky, and J. Kurths, Phys. Rev. Lett. **76**, 1804 (1996).
 - [5] M.G. Rosenblum, A.S. Pikovsky, and J. Kurths, Phys. Rev. Lett. **78**, 4193 (1997).
 - [6] S. Taherion and Y.-C. Lai, Phys. Rev. E **59**, 6247 (1999); Int. J. Bifurcation Chaos Appl. Sci. Eng. **10**, 2587 (2000).
 - [7] O.V. Sosnovtseva, A.G. Balanov, T.E. Vadivasova, V.V. Astakhov, and E. Mosekilde, Phys. Rev. E **60**, 6560 (1999).
 - [8] S. Boccaletti and D. Valladares, Phys. Rev. E **62**, 7497 (2000).
 - [9] H.U. Voss, Phys. Rev. E **61**, 5115 (2000).
 - [10] O.E. RöSSLer, Phys. Lett. **57A**, 397 (1976).
 - [11] R. Madan, *Chua's Circuit: A Paradigm for Chaos* (World Scientific, Singapore, 1993).
 - [12] M.P. Kennedy, Frequenz **46**, 66 (1992).
 - [13] The cross-spectral density is typically quite noisy in the high-frequency regime. The linear regression of $\Phi_{12}(\omega)$ is meaningful only in the low-frequency regime.
 - [14] K. Josić, Phys. Rev. Lett. **80**, 3053 (1998).
 - [15] E. Barreto, P. So, B.J. Gluckman, and S.J. Schiff, Phys. Rev. Lett. **84**, 1689 (2000); E. Barreto and P. So, *ibid.* **85**, 2490 (2000).